

At any very moment, living cells are sending and receiving millions of messages in the form of physical signals or chemical signaling molecules.

In order to detect a chemical signal, a cell (**target cell**) must have the right **receptor** for that signal (**ligand**).

When a ligand specifically binds to its receptor, it alters the shape or activity of the receptor, triggering a change (**response**) inside of the cell.

Not all cells can sense a particular chemical message.

Physical signals are generally converted to chemical signals at the level of the receptor (photo-receptors; pressure-sensing channels).

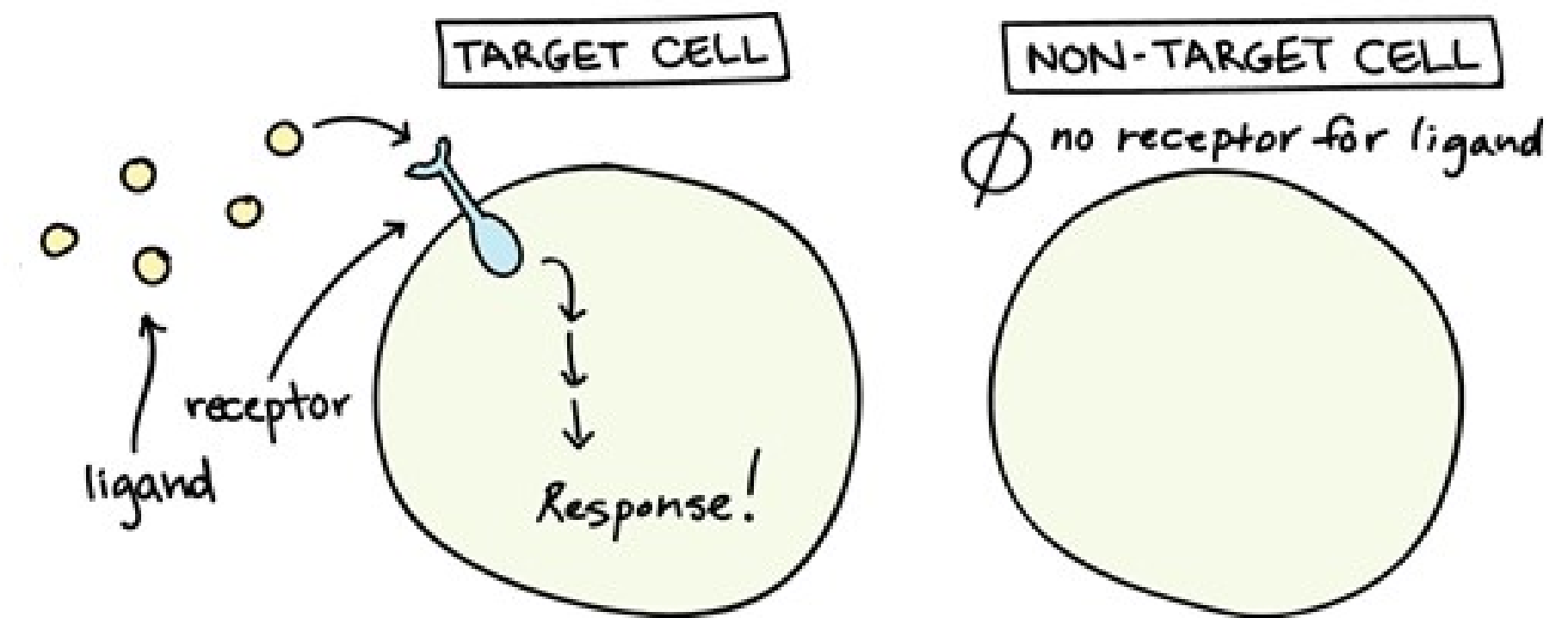

At any very moment, living cells are sending and receiving millions of messages in the form of physical signals or chemical signaling molecules.

The signals are often relayed through a chain of chemical messengers inside the cell. Ultimately, this phenomenon leads to a change in the cell (e.g. alteration in the activity of a gene, the induction of a whole process such as cell division). Thus, the original extra-cellular signal is converted into an intra-cellular signal that triggers a response.

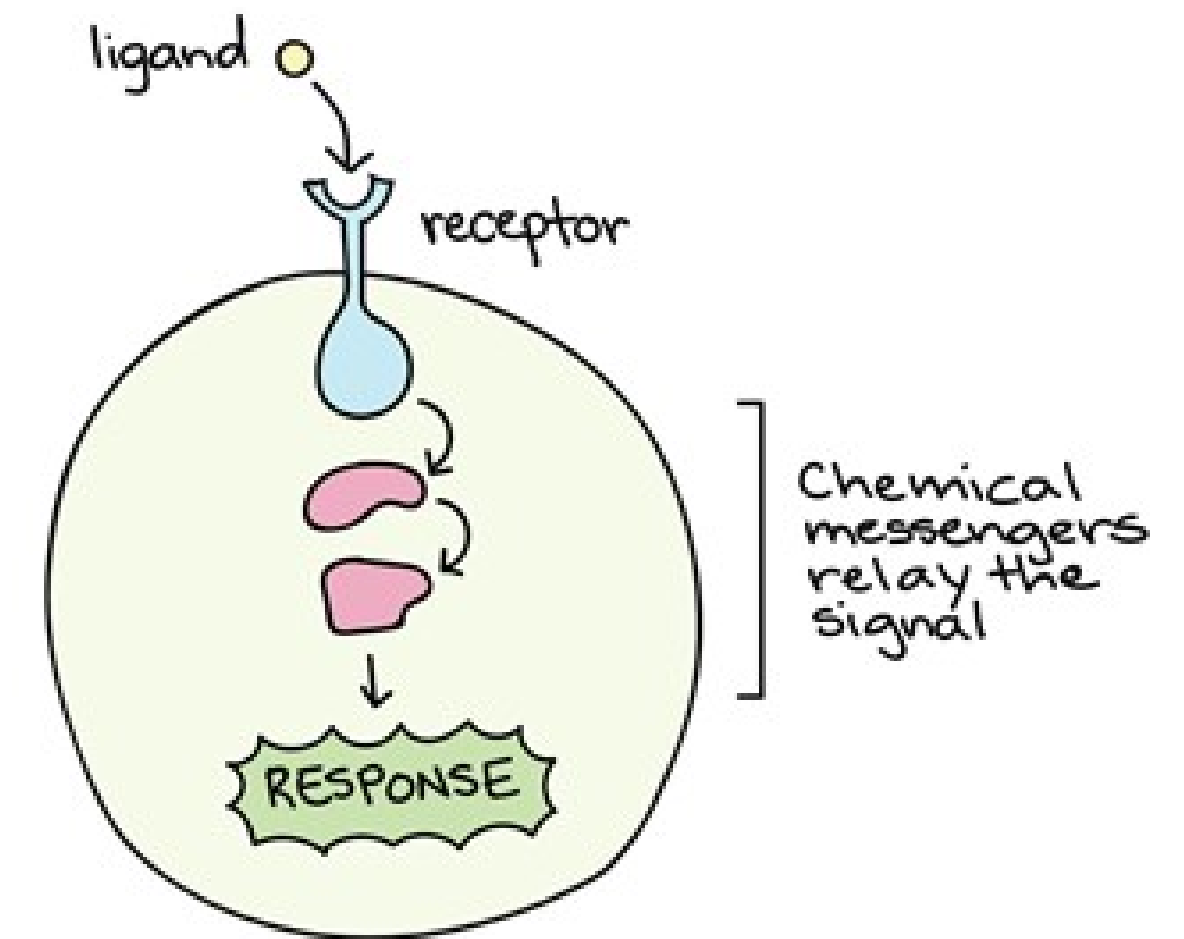

At any very moment, living cells are sending and receiving millions of messages in the form of physical signals or chemical signaling molecules.

Ligands produced by signaling cells come in many different varieties and interact with receptors on the outside of target cells or inside.

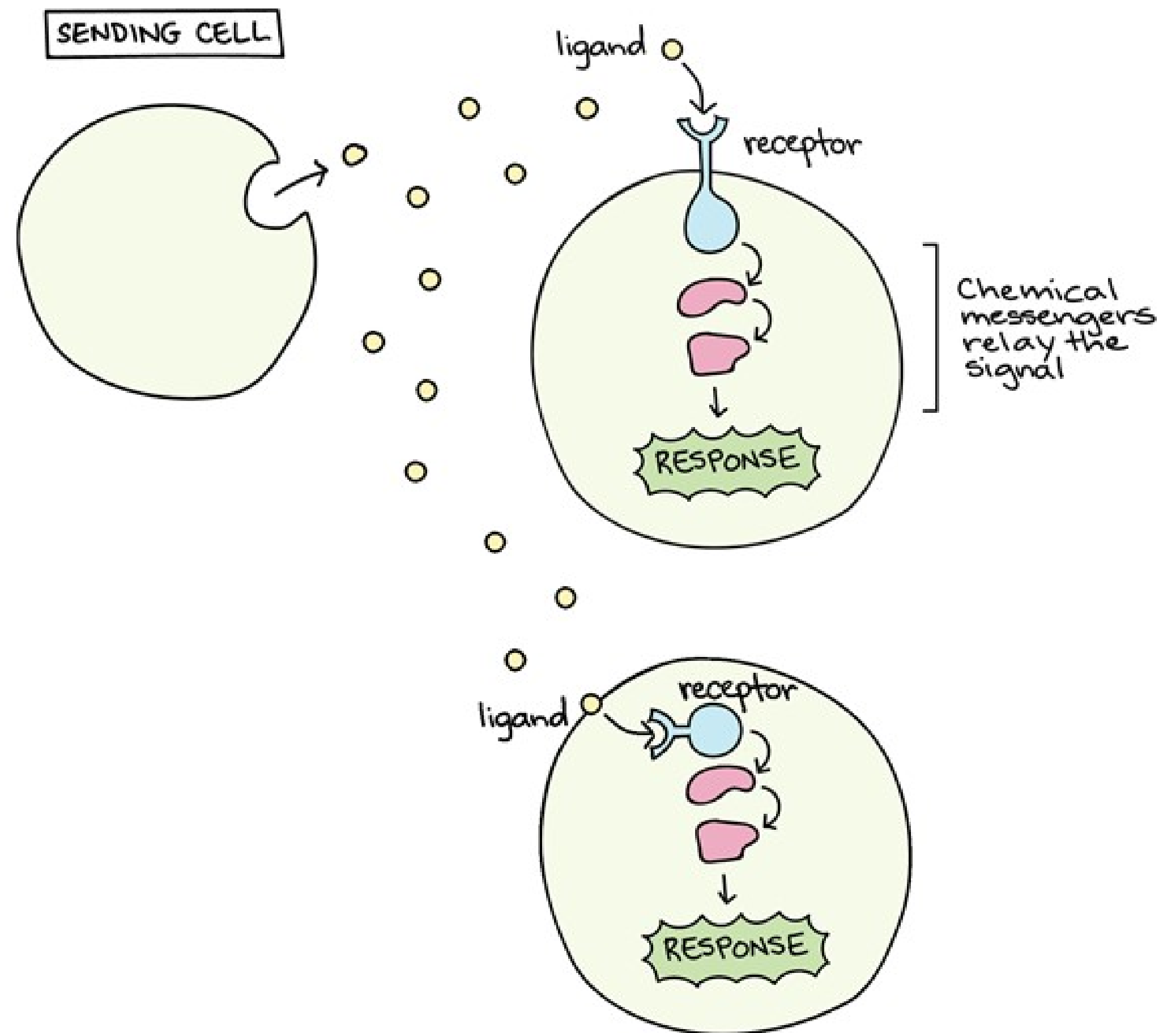

Basic categories of chemical signaling in multicellular organisms:



PARACRINE SIGNALING

Released ligands diffuse through the space between the cells. Cells communicate over relatively short distances (immediate surrounding area) to locally coordinate activities with nearby target cells (e.g. tissue development; synaptic signaling).

AUTOCRINE SIGNALING

A cell signals to itself, releasing ligands that bind to receptors on its own surface (or to receptors inside of the same cell). In many cases, a signal may have both autocrine and paracrine effects.

CELL-CELL CONTACT SIGNALING

Small signaling molecules (intracellular mediators) diffuse between two neighbouring cells directly connected by water-filled channels (e.g. gap junctions in animals and plasmodesmata in plants). This allows a group of cells to coordinate their response to a signal that only one of them may have received.

ENDOCRINE SIGNALING

Signaling molecules produced in one part of the body (in endocrine glands) can affect other body regions some distance away. Ligands (hormones) travel the large distances between endocrine cells and their target cells via the bloodstream (a relatively slow way to move throughout the body). At difference from paracrine signaling, in which local concentrations of ligands can be very high, hormones get diluted because of their form of transport and are present in low concentrations when they act on their target cells.

The main difference between the various categories of signaling is the distance that the signal travels through the organism to reach the target cell.

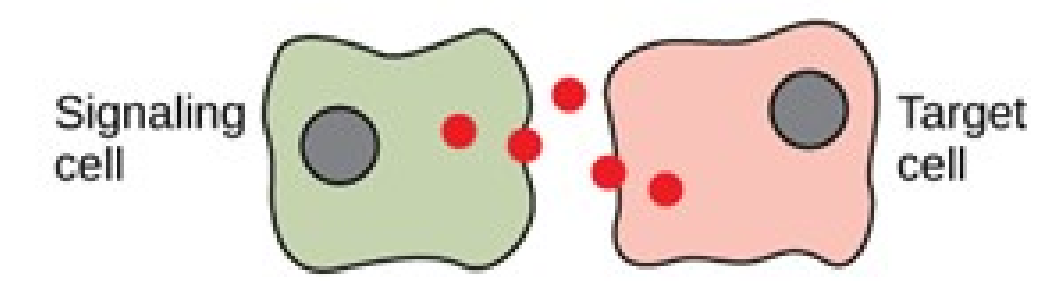
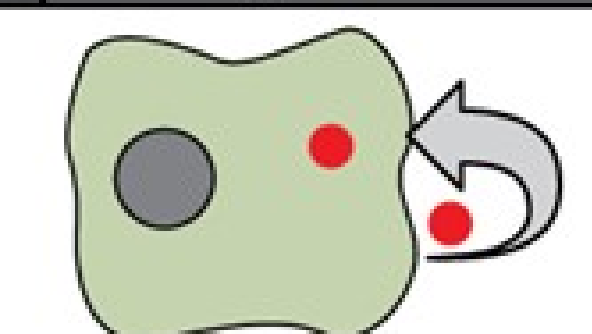
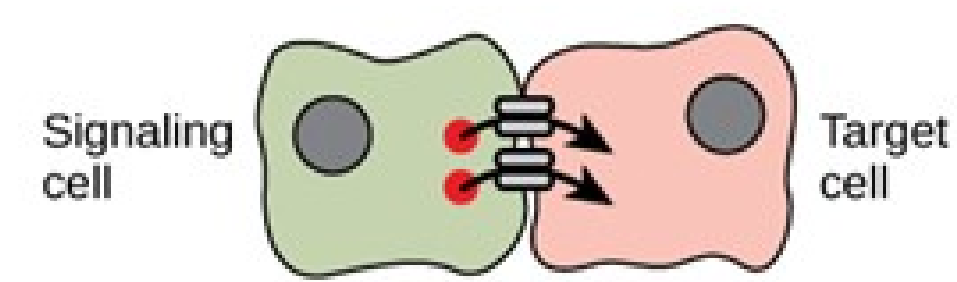
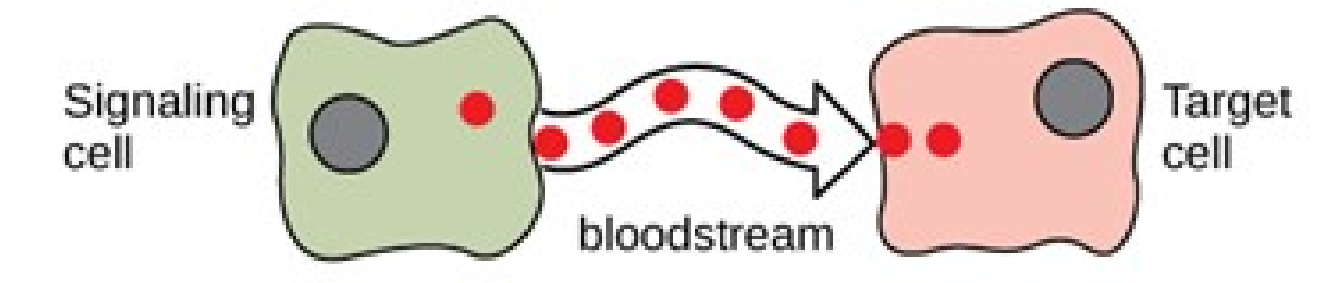
Paracrine	A cell targets a nearby cell.
	
Autocrine	A cell targets itself.
	
Signaling across gap junctions	A cell targets a cell connected by gap junctions.
	
Endocrine	A cell targets a distant cell through the bloodstream.
	

The receptor's **two-domain nature** allows the cell to regulate the **binding of ligand** and the **effect of ligand** independently.

Receptor modularity allows a wide variety of signals to use a limited number of cell regulatory mechanisms (e.g. outputs)

Expression of a receptor that is not normally expressed in a cell is often sufficient to confer responsiveness to that receptor's ligand. This responsiveness often occurs because the cell already expresses the other components necessary for propagating the intracellular signal from the receptor.

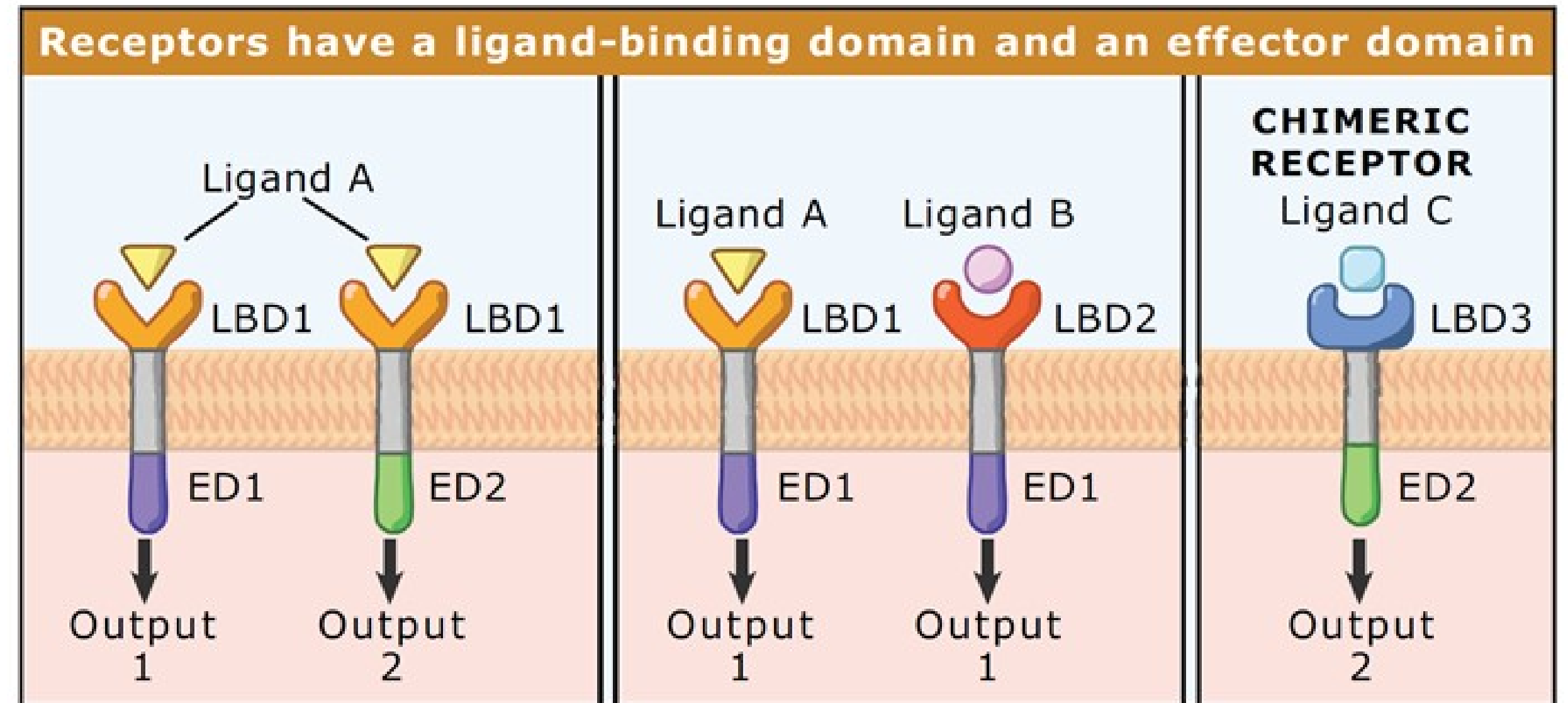

one can create an artificial chimeric receptor with novel properties

Two receptor isoforms that respond to the **same ligand** with **distinct effects** mediated by **different effector domains** (e.g. Acetylcholine)

Two receptors that respond to **different ligands** could initiate the **same function** by activating **similar effector domains** (e.g. production of the intracellular signaling molecule cAMP)

Receptors act to **accelerate intracellular functions** and are, thus, functionally analogous to enzymes or other catalysts.

Some receptors are themselves enzymes (e.g. protein kinases) and thus classical biochemical catalysts.

- **Specificity**

Precise molecular complementarity between the signal and receptor molecules (weak, reversible, non-covalent forces)

In multicellular organisms, also cell type/tissue specificity

- **Affinity**

high K_a , low $K_d = [R][L] / [RL] \leq 10^{-7} \text{ M}$

The Receptor detects micromolar to nanomolar concentrations of the Ligand

- **Saturation**

(R may be present in very low quantities in the cell)

- **Cooperativity**

Large changes in receptor activation with small changes in ligand concentration

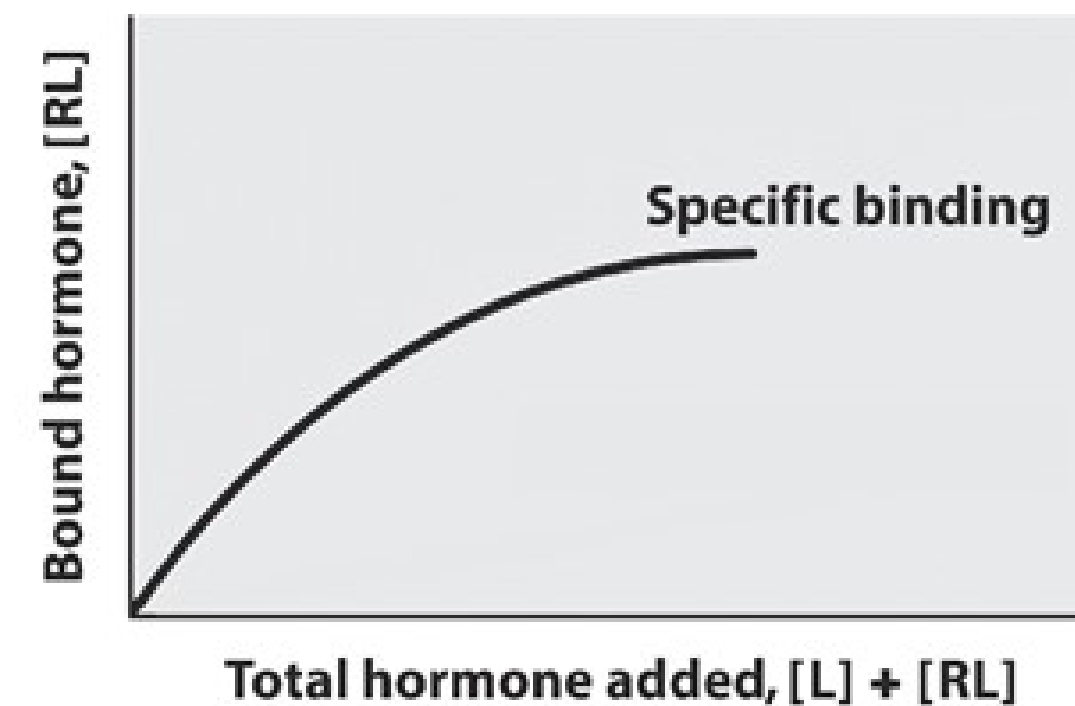
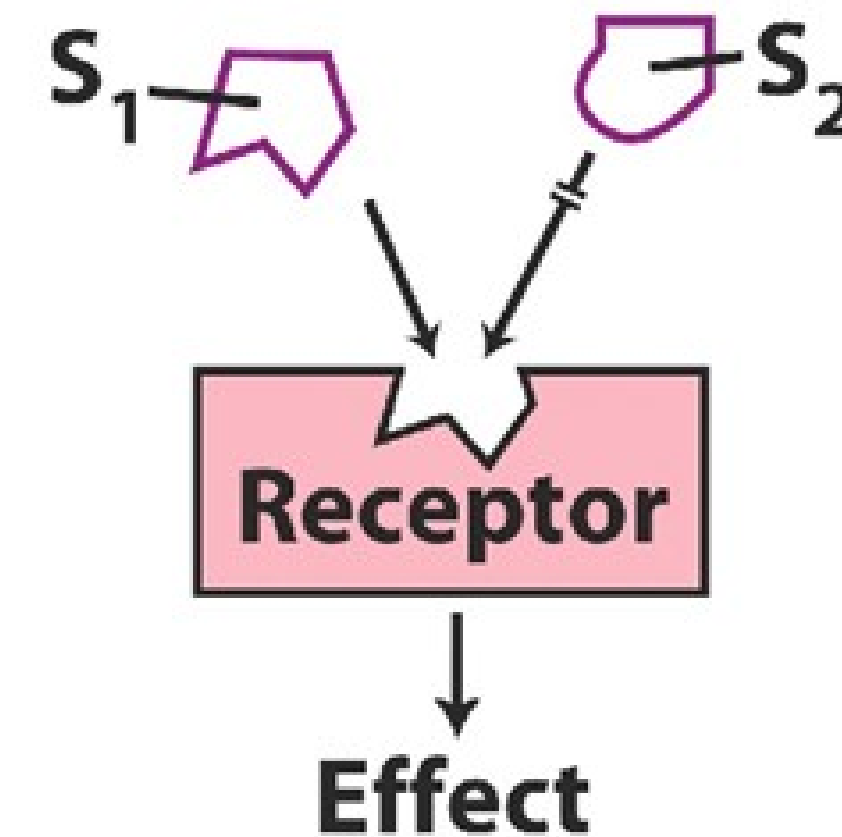

In all signaling reactions, receptors use their catalytic activities to **function as molecular amplifiers**.

- **Amplification**

The RL complex activates an enzyme that, in turn, catalyzes the activation of many molecules of a second enzyme and so on (**enzyme cascade**)

The number of affected molecules increases geometrically within milliseconds

- **Integration**

Multiple signals (with opposite/similar effects) combine to produce a **unified response**

The reactions function as mathematical logic functions to integrate information

- **Desensitization/Adaptation**

When a signal is present continuously, R no longer responds until the stimulus falls below a certain threshold, then sensitivity slowly returns to normal (**feedback circuit**)

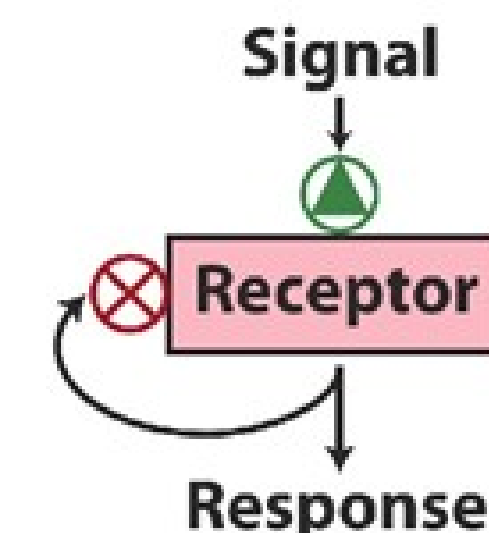
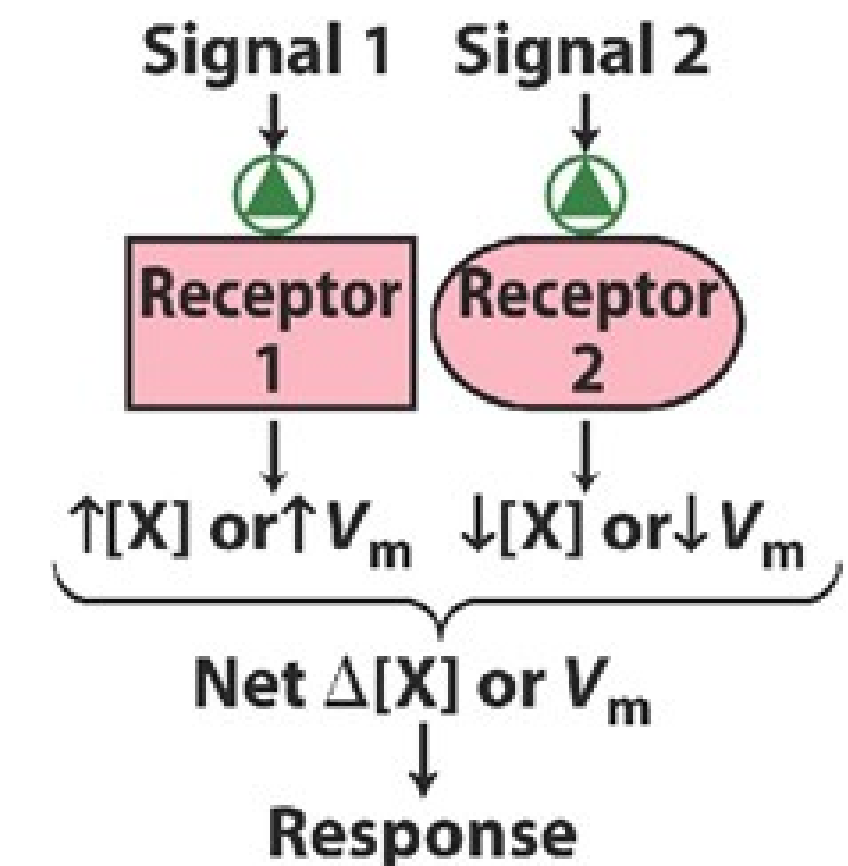
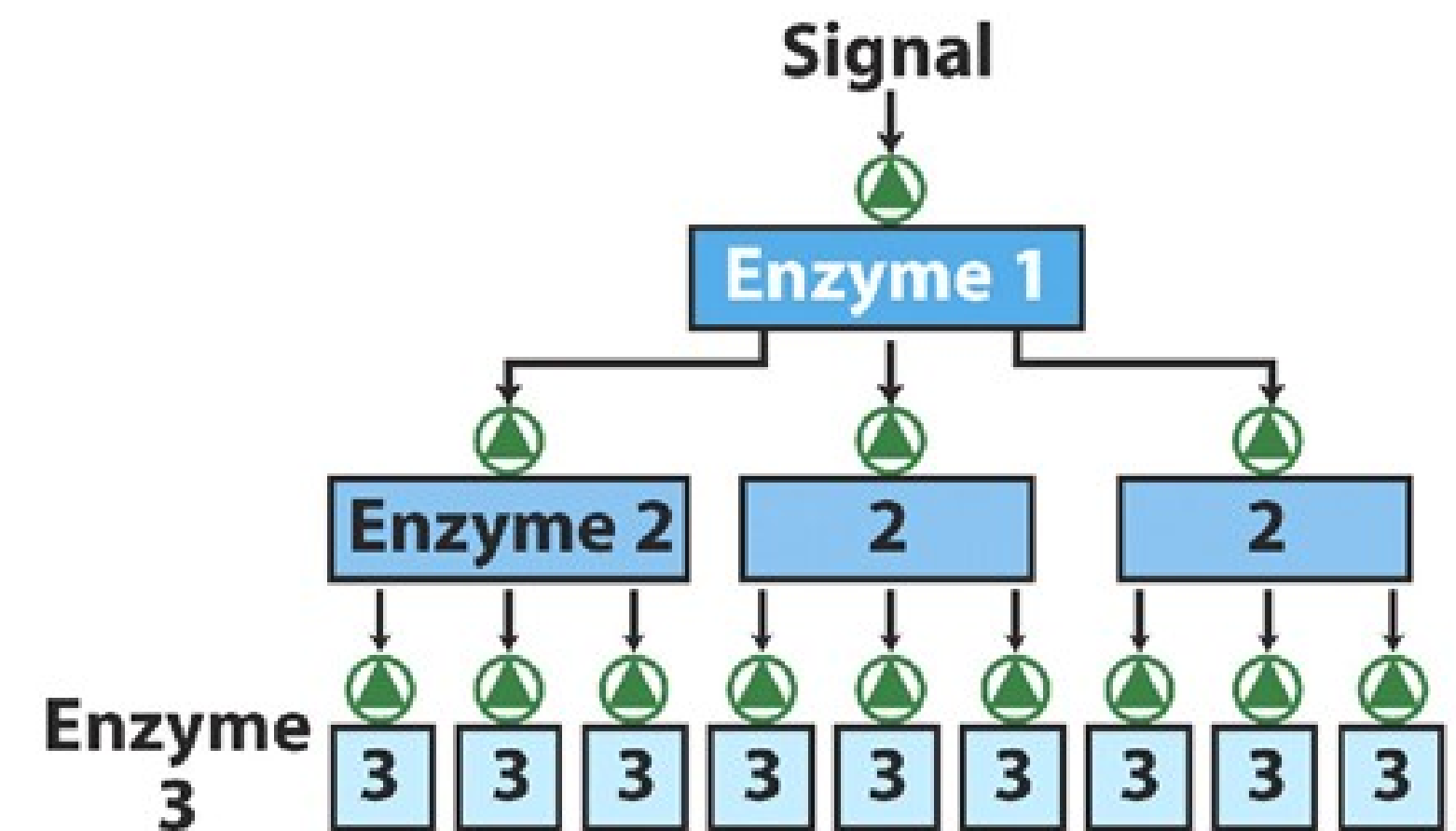

Del Castillo and Katz based their model on ion channel receptors (e.g., the muscle ACh receptor that causes Na^+ influx and depolarization) but it was also thought to represent other receptor mechanisms. A later version of the two-state model suggests that receptors exist in one of two conformations – R or R^* – with the understanding that R^* can exist even in the absence of agonist; the binding of agonist stabilizes the receptor in that state and promotes activity. At the time it was not known whether any cellular activity might occur without receptor binding. This idea is shown in Figure 5.8 (based on Equation 3.14 in Ref. [120]).

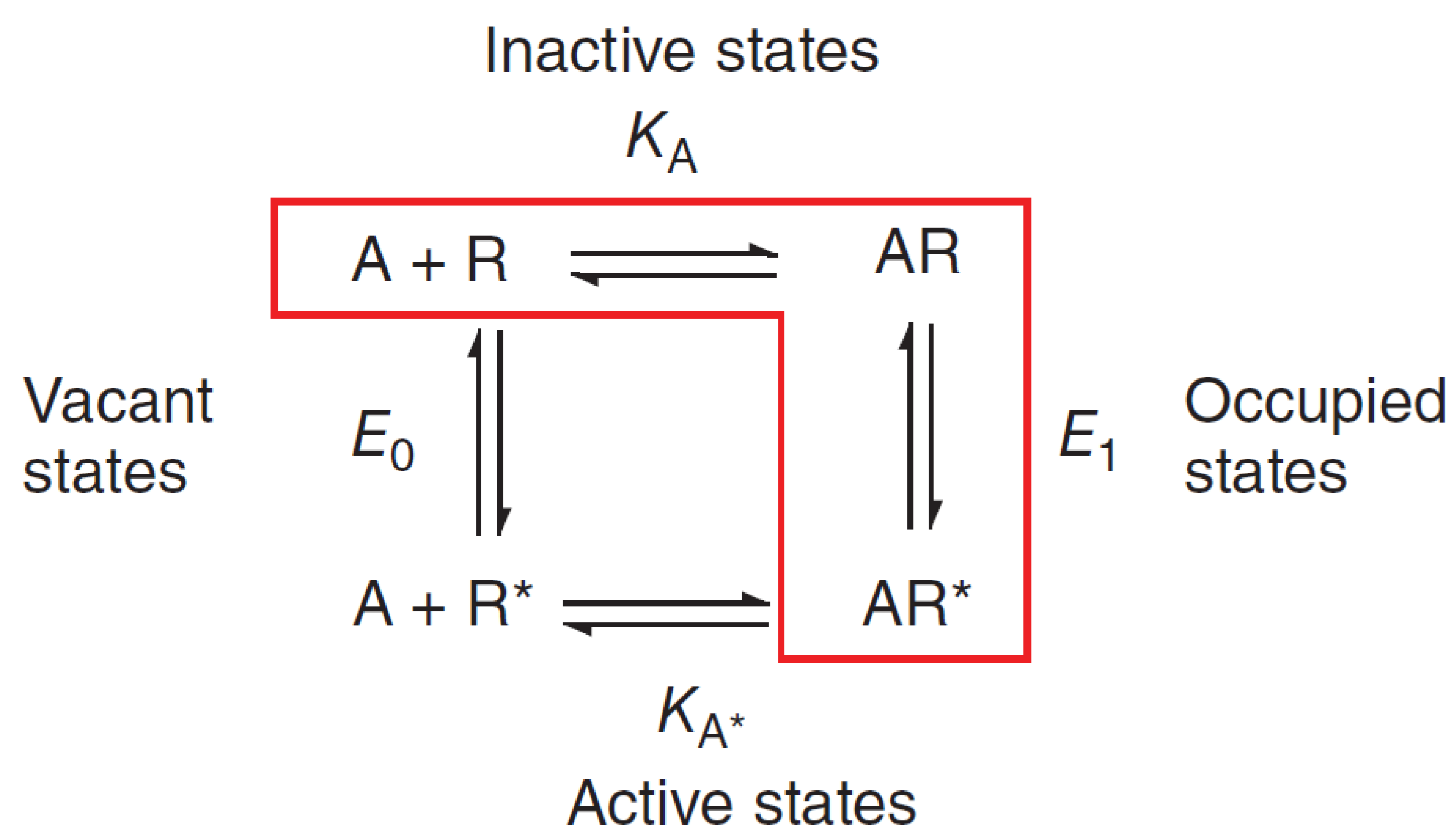

Figure 5.8 Two aspects of the two-state model of receptor activation. The boxed series represents classical hypotheses of affinity (K_A) and efficacy (E_1) according to the occupancy model and the Del Castillo and Katz [128] model. The remainder illustrates alterations accounting for active unbound receptors (E_0) and conformational change of receptor upon agonist binding (K_{A^*}).

This model suggests the existence of four separate receptor states, two relating to occupation and two relating to activity; these states are governed by four kinetic constants. The earlier classical models proposed that all unbound receptors are R, and are inactive. Agonist binding produces the occupied state AR, which only then converts to the active state AR^* . In contrast, the two-state model proposes that R may change conformation to an active R^* in the absence of A. The agonist A may bind to either state, but it has a higher affinity for R^* . As the AR^* conformation is the active one, the binding of A to R^* stabilizes the active state, producing a cellular response.

Even though it considers spontaneous conformational changes, the two-state model does not reflect the types of interactions that occur between the receptor and **allosteric** proteins, for example, in the GPCRs. Thus, it has always been less inappropriate for the GPCR superfamily of receptors.